

Refurbishment Felt Support Tray

CODE **G1281**

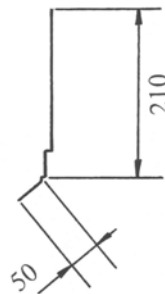
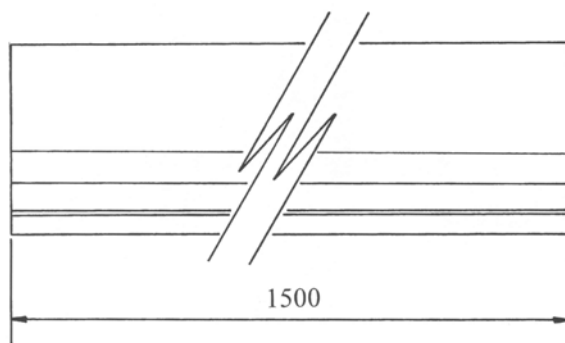
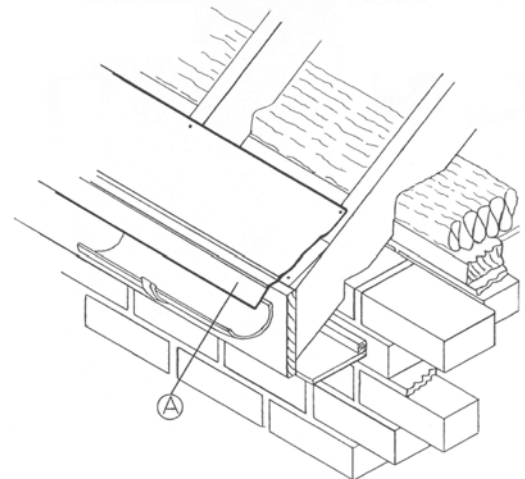
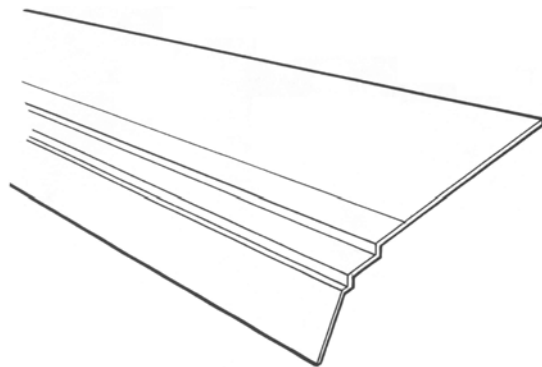

Description:

The G1281 Refurbishment Felt Support Tray is designed predominately for replacement of old perished felt at eaves level caused by the sagging and subsequent 'ponding' of water.

Alternatively it can be used in new build situations and suits all rafter centres.

Fitting Instructions:

The G1281 Refurbishment Felt Support Tray (A) should be pushed under existing felt in refurbishment situations.

Alternatively in new build situations felt should be dressed over the tray. The support tray should be positioned on top of the fascia boards and secured to the roof trusses. Joints should be overlapped by minimum of 150mm.

Use in conjunction with other products from the Manthorpe range to provide a complete roof ventilation system.

COLOURS	Black, Grey
PACKING DETAILS	Packed in 10's in poly sleeve
WEIGHT	12.2kg per box
MATERIAL	PVC
MANUFACTURING PROCESS	Extrusion

References:

BRE:	DIGEST 14
BSI:	BS5534
NFRC:	Technical Bulletin 6/21
NHBC:	Standards 7.2
P.S.A:	Defects in Buildings

MANTHORPE BUILDING PRODUCTS LTD
MANTHORPE HOUSE
BRITAIN DRIVE
CODNOR GATE BUSINESS PARK
RIPLEY
DERBYSHIRE DE5 3ND

TEL: 01773 514 200
FAX: 01773 514 262
EMAIL:
sales@manthorpe.co.uk
WEB:
www.manthorpe.co.uk

DRN M.A

Date 01.08.03

DRG No

Issue

The company maintains a policy of continuous development of its product range and reserves the right to amend the specification without notice.

MBP 8075

A